

Execution of special geotechnical works — Jet grouting

<https://geotechnicaldesign.info/en1537-1999.html>

The European Standard EN 12716:2001 has the status of a
British Standard

ICS 93.020

National foreword

This British Standard is the official English language version of EN 12716:2001.

The UK participation in its preparation was entrusted by Technical Committee B/526, Geotechnics, to Subcommittee B/526/4, Strengthened reinforced soils and other fills, which has the responsibility to:

- aid enquirers to understand the text;
- present to the responsible European committee any enquiries on the interpretation, or proposals for change, and keep the UK interests informed;
- monitor related international and European developments and promulgate them in the UK.

A list of organizations represented on this subcommittee can be obtained on request to its secretary.

Cross-references

The British Standards which implement international or European publications referred to in this document may be found in the BSI Standards Catalogue under the section entitled “International Standards Correspondence Index”, or by using the “Find” facility of the BSI Standards Electronic Catalogue.

A British Standard does not purport to include all the necessary provisions of a contract. Users of British Standards are responsible for their correct application.

Compliance with a British Standard does not of itself confer immunity from legal obligations.

This British Standard, having been prepared under the direction of the Sector Committee for Building and Civil Engineering, was published under the authority of the Standards Committee and comes into effect on 15 August 2001

Summary of pages

This document comprises a front cover, an inside front cover, the EN title page, pages 2 to 35 and a back cover.

The BSI copyright date displayed in this document indicates when the document was last issued.

Amendments issued since publication

Amd. No.	Date	Comments

ICS 93.020

English version

Execution of special geotechnical works - Jet grouting

Exécution des travaux géotechniques spéciaux - Colonnes,
panneaux et structures de sol-ciment réalisés par jet

Ausführung von besonderen geotechnischen Arbeiten
(Spezialtiefbau) - Düsenstrahlverfahren
(Hochdruckinjektion, Hochdruckbodenvermörtelung,
Jetting)

This European Standard was approved by CEN on 16 April 2001.

CEN members are bound to comply with the CEN/CENELEC Internal Regulations which stipulate the conditions for giving this European Standard the status of a national standard without any alteration. Up-to-date lists and bibliographical references concerning such national standards may be obtained on application to the Management Centre or to any CEN member.

This European Standard exists in three official versions (English, French, German). A version in any other language made by translation under the responsibility of a CEN member into its own language and notified to the Management Centre has the same status as the official versions.

CEN members are the national standards bodies of Austria, Belgium, Czech Republic, Denmark, Finland, France, Germany, Greece, Iceland, Ireland, Italy, Luxembourg, Netherlands, Norway, Portugal, Spain, Sweden, Switzerland and United Kingdom.



EUROPEAN COMMITTEE FOR STANDARDIZATION
COMITÉ EUROPÉEN DE NORMALISATION
EUROPÄISCHES KOMITEE FÜR NORMUNG

Management Centre: rue de Stassart, 36 B-1050 Brussels

Contents

	page
Foreword.....	3
1 Scope	4
2 Normative references	4
3 Terms and definitions.....	4
4 Specific needs	11
5 Geotechnical investigation	12
6 Materials.....	13
7 Design considerations	14
7.1 General.....	14
7.2 Geometry	17
7.3 Strength and Deformation Characteristics	17
7.4 Permeability.....	17
8 Execution	18
8.1 General.....	18
8.2 Equipment.....	19
8.3 Preliminary works	20
8.4 Drilling.....	20
8.5 Jet grouting	21
8.6 Spoil Return.....	21
8.7 Placing the reinforcement.....	21
9 Supervision, testing and monitoring	21
9.1 General.....	21
9.2 Preliminary tests	22
9.3 Supervision and process testing	22
9.4 Testing on the constructed elements	23
9.5 Monitoring.....	24
10 Execution documents.....	24
10.1 Documents available on site.....	24
10.2 Documents to be produced on site.....	25
11 Special requirements.....	25
11.1 Compliance with national standards	25
11.2 Site safety	25
11.3 Protection of the environment.....	26
Annex A (normative) Additional design requirements	27
Annex B (informative) Ranges of jet grouting parameters.....	28
Annex C (informative) Indirect tests	29
Annex D (informative) Examples of site records of jet grouting works.....	30
Annex E (informative) Degree of obligation of the provisions	33
Bibliography	35

Foreword

This European Standard has been prepared by Technical Committee CEN /TC 288, "Execution of special geotechnical works", the secretariat of which is held by AFNOR.

This European Standard shall be given the status of a national standard, either by publication of an identical text or by endorsement, at the latest by November 2001, and conflicting national standards shall be withdrawn at the latest by November 2001.

Annex A is normative, and the annexes B, C, D and E are informative.

According to the CEN/CENELEC Internal Regulations, the national standards organizations of the following countries are bound to implement this European Standard: Austria, Belgium, Czech Republic, Denmark, Finland, France, Germany, Greece, Iceland, Ireland, Italy, Luxembourg, Netherlands, Norway, Portugal, Spain, Sweden, Switzerland and the United Kingdom.

1 Scope

This Standard is applicable to the execution, testing and monitoring of jet grouting works. Design considerations, strictly related to jet grouting works only, are given in clause 7. More general requirements that could be included in, or substituted by clauses of future editions of Eurocode 7 are listed in Annex A.

NOTE The jet grouting processes should be distinguished from the grouting processes covered by EN 12715.

2 Normative references

This European Standard incorporates by dated or undated reference, provisions from other publications. These normative references are cited at the appropriate places in the text and the publications are listed hereafter. For dated references, subsequent amendments to or revisions of any of these publications apply to this European Standard only when incorporated in it by amendment or revision. For undated references the latest edition of the publication referred to applies (including amendments).

ENV 197-1:1992, *Cement - Composition, specifications and conformity criteria - Part 1: Common cements*

prEN 1008:1997, *Mixing water for concrete - Specification for sampling, testing and assessing the suitability of water, including wash water from recycling installations in the concrete industry, as mixing water for concrete*

ENV 1992-1-1:1991, *Eurocode 2: Design of concrete structures - Part 1: General rules and rules for buildings*

ENV 1997-1:1994, *Eurocode 7: Geotechnical design - Part 1: General rules*

3 Terms and definitions

For the purposes of this European Standard, the following terms and definitions apply:

3.1

jet grouting

the jet grouting process consists of the disaggregation of the soil or weak rock and its mixing with, and partial replacement by, a cementing agent; the disaggregation is achieved by means of a high energy jet of a fluid which can be the cementing agent itself

3.2

jet grouted element

a volume of soil treated through a single borehole. The most common elements are :

- jet grouted column : a cylindrical jet grouted element (Fig.1 a) ;
- jet grouted panel : a planar jet grouted element (Fig.1 b).

3.3

jet grouted structure

an assembly of jet grouted elements which are partially or fully interlocked. The most common structures formed are :

- jet grouted diaphragm : a wall structure (Fig.2 a) ;
- jet grouted slab : a horizontal structure formed by essentially vertical jet grouting (Fig.2 b) ;
- jet grouted canopy : a structure formed by horizontal jet grouting – see 3.8 below (Fig.2 c) ;
- jet grouted block : a three-dimensional structure.

3.4

single system

the jet grouting process in which the disaggregation and cementation of soil are achieved by a high energy jet of a single fluid, usually a cement grout (Fig.3 a)

3.5

double (air) system

the jet grouting process in which the disaggregation and the cementation of soil are achieved by one high energy fluid (usually a cement grout) assisted by an air jet shroud as a second fluid (Fig.3 b)

3.6

double (water) system

the jet grouting process in which the disaggregation of the soil is achieved by a high energy water jet and its cementing is simultaneously obtained by a separate grout jet (Fig.3 c)

3.7

triple system

the jet grouting process in which the disaggregation of the soil is achieved by a high energy water jet assisted by an air jet shroud, and its cementing is simultaneously obtained by a separate grout jet (Fig.3 d)

NOTE In special cases the water can be substituted for other appropriate liquids or suspensions.

3.8

horizontal jet grouting

treatment performed from a horizontal or sub-horizontal borehole (within $\pm 20^\circ$ from the horizontal plane)

3.9

jet grouting rig

rotary rig able to automatically regulate the rotation and translation of the jet grouting string and tool

3.10

jet grouting string

jointed rods, with simple, double or triple inner conduit, which convey the jet grouting fluid(s) to the monitor

3.11

monitor

the tool mounted at the end of the jet grouting string, to enable jetting of the fluids into the ground

3.12

nozzle

a specially manufactured device fitted into the monitor and designed to transform the high pressure fluid flow in the string into the high speed jet directed at the soil

3.13

radius of influence

effective distance of disaggregation of soil by the jet, measured from the axis of the monitor

3.14

spoil return

the surplus mixture of soil particles and introduced fluids arising from the jet grouting process, and normally flowing to the ground surface via the annulus of the jetting borehole

3.15

jet grouting parameters

the jet grouting parameters are defined :

- pressure of the fluid(s) within the jet grouting string ;
- flow rate of the fluid(s) within the jet grouting string ;
- grout composition ;
- rotation speed of the jet grouting string ;

— rate of withdrawal or insertion of the jet grouting string.

**3.16
prejetting**

the method in which the jet grouting of an element is facilitated by a preliminary disaggregation phase, with a jet of water and/or other fluids

NOTE Prejetting is also widely known as prewashing or precutting.

**3.17
fresh-in-fresh sequence**

the sequence of work in which the jet grouted elements are constructed successively without waiting for the grout to harden in the overlapping elements (Fig.4 a)

**3.18
primary-secondary sequence**

the sequence of work in which the execution of an overlapping element cannot commence before a specified hardening time or achievement of predetermined strength of the adjacent elements previously constructed (Fig.4 b)

**3.19
jet grouted material**

the material which constitutes the body of a jet grouted element

**3.20
reinforced jet grouting**

jet grouted columns reinforced by steel or other high strength material

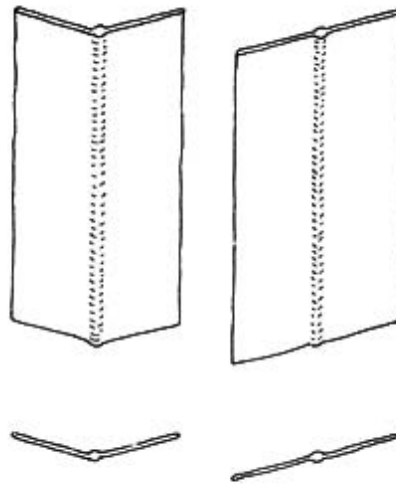

Figure 1 a) — Jet grouted column

Figure 1 b) — Jet grouted panel

Figure 1 — Examples of jet grouted elements

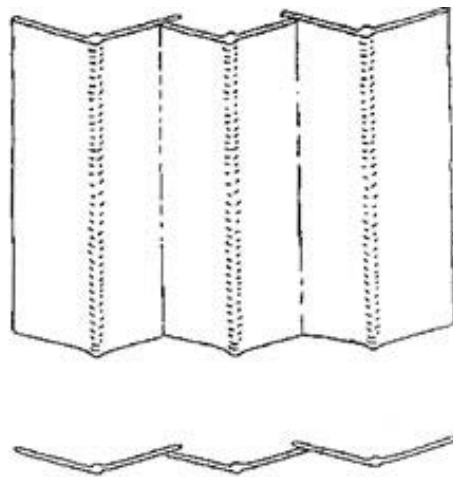
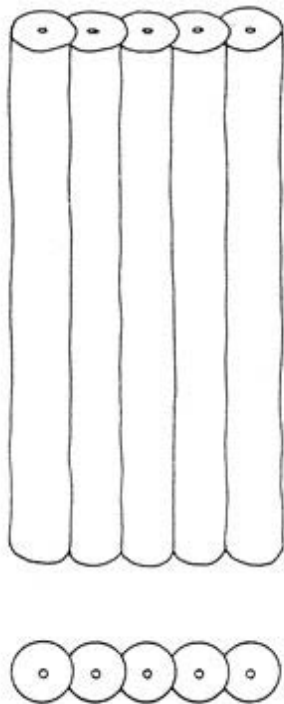

Figure 2 a) — Jet grouted diaphragms

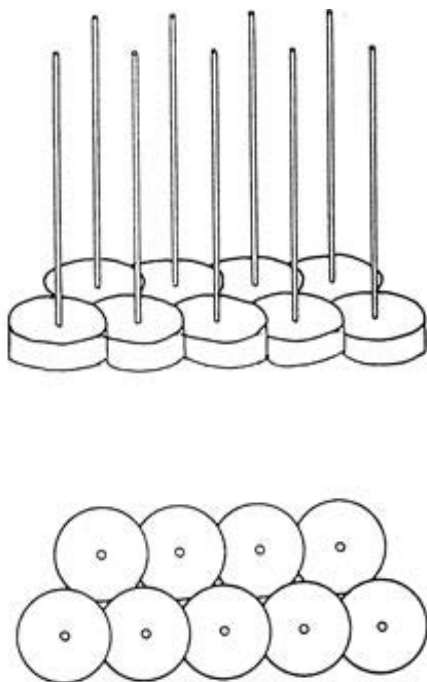

Figure 2 b) — Jet grouted slab

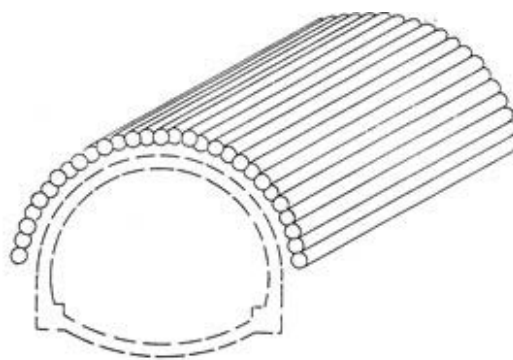
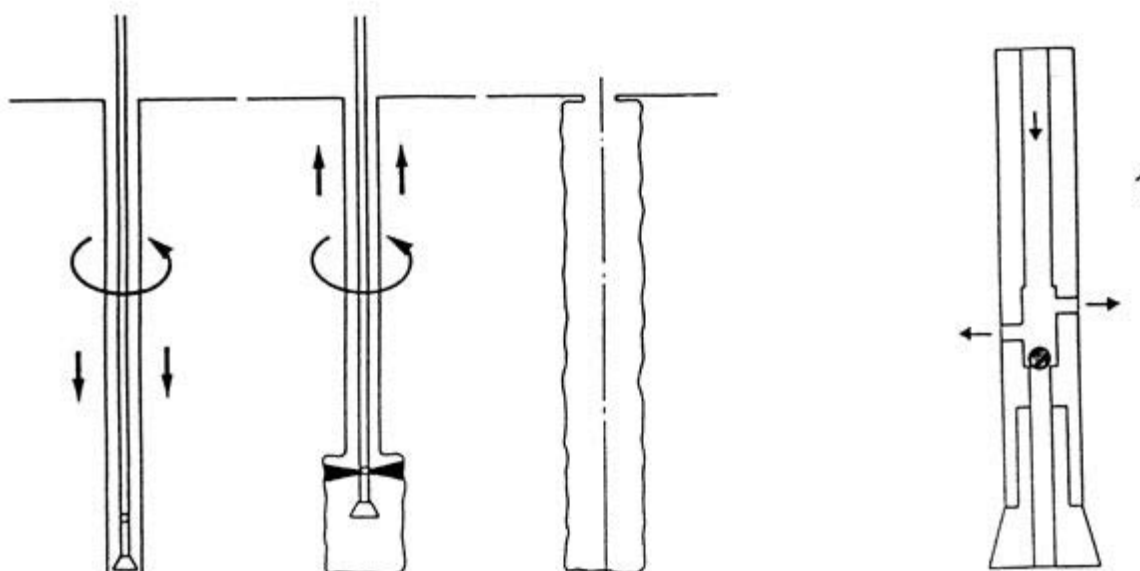

Figure 2 c) — Jet grouted canopy

Figure 2 — Examples of jet grouted structures



Key

1 Monitor

Figure 3 a) — Single system

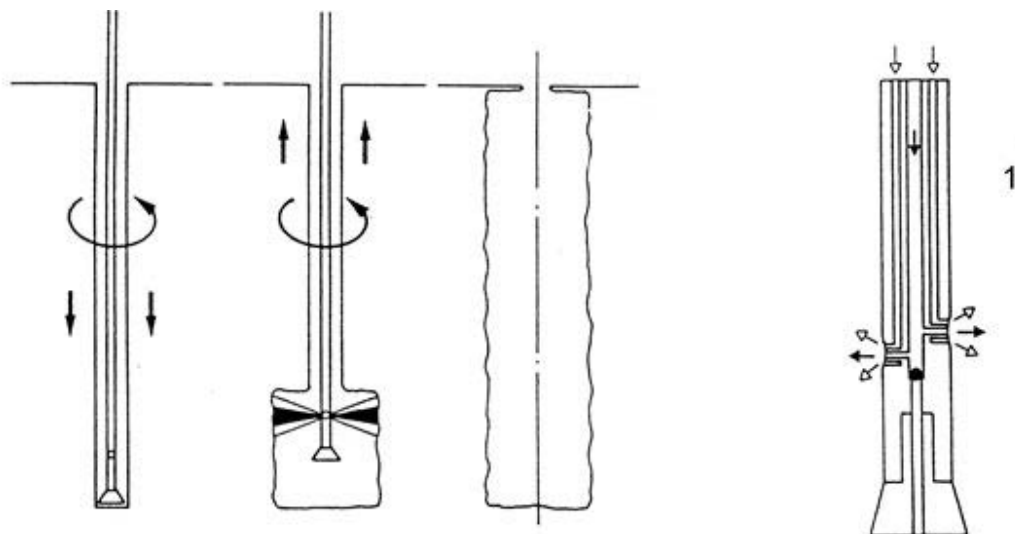

Key

1 Monitor

Figure 3 b) — Double (air) system

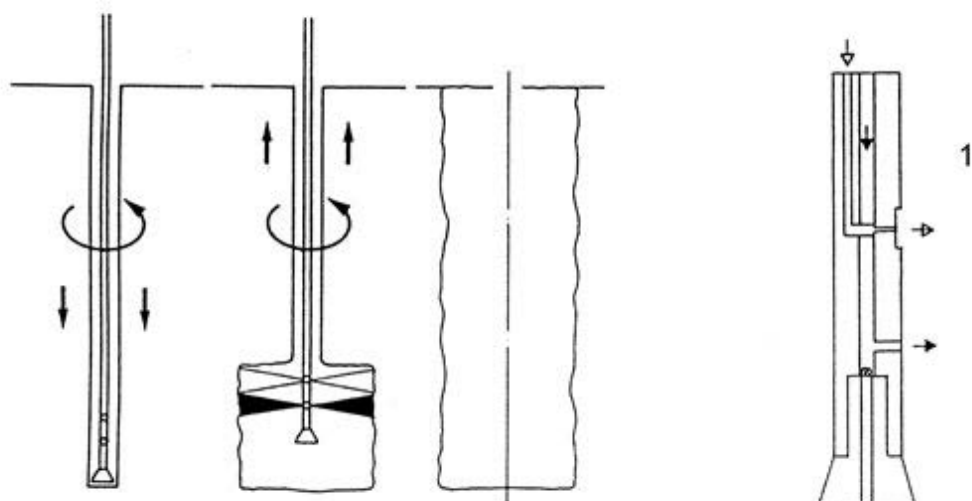

Key

1 Monitor

Figure 3 c) — Double (water) system

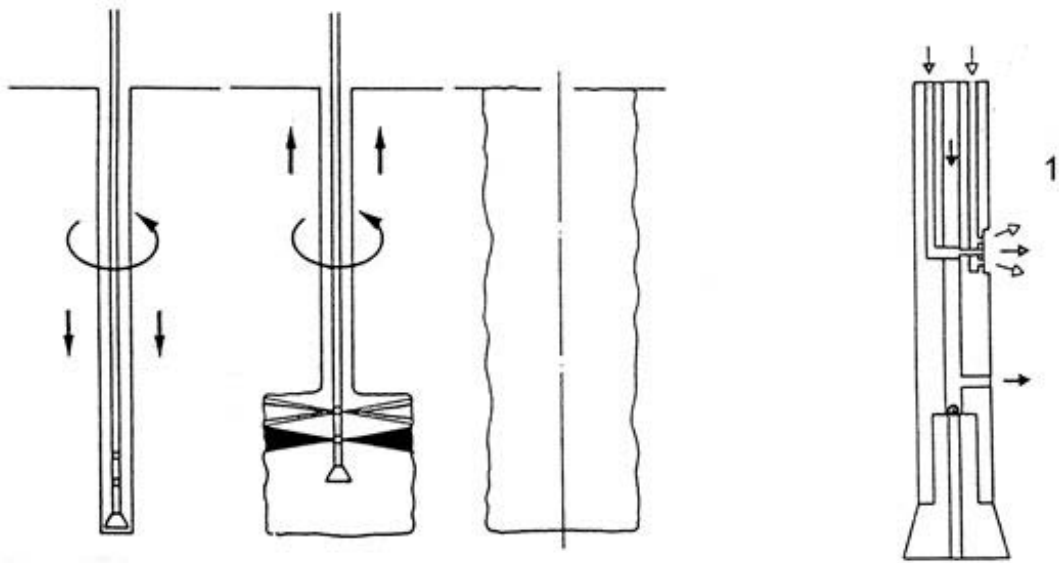

Key

1 Monitor

Figure 3 d) — Triple system

Figure 3 — Schemes of jet grouting systems

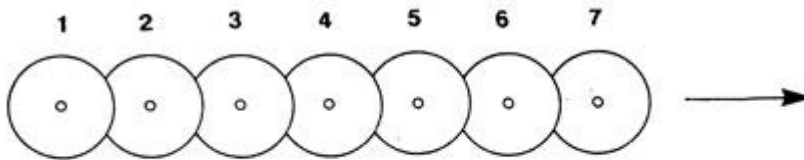

Figure 4 a) — Fresh in fresh sequence

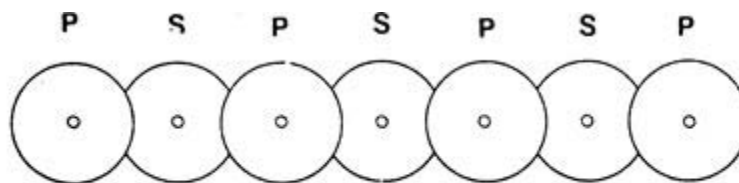

Figure 4 b) — Primary - secondary sequence

Figure 4 — Work sequences

4 Specific needs

4.1 The following information shall be determined prior to design or execution activities :

— detailed description of the ground profile and its geotechnical properties within the intended extent of treatment ;

and, as appropriate :

— hydrogeological conditions ;

— boundary conditions (adjacent structures, buried structures and services, overhead power lines and other working restrictions, access) ;

— environmental requirements; in particular disposal of spoil return ;

— acceptable deformation of the structures to be underpinned or of adjacent structures.

4.2 Design assumptions according to ENV 1997-1-1:1994 - clause 2 shall be verified, and modified if necessary, according to information obtained during the execution phase.

4.3 Due to the nature of jet grouting works, the client, the main contractor, a specialist contractor or a consulting engineer, may perform all or parts of the design.

4.4 The allocation of design, execution and supervision activities and responsibilities of all the parties involved shall be legibly specified in the contract documents.

4.5 Design and execution should include, as appropriate, the activities listed in table 1. The order shown does not necessarily represent a time sequence.

Table 1 — Recommended list of activities in the design and execution of jet grouting

N°	Activity
1	Provision of site investigation data for execution of jet grouting works.
2	Decision to use jet grouting, preliminary trials and testing if required ; provision of a specification.
3	Acquisition of all legal authorization necessary for the execution from authorities and third parties.
4	Overall design of jet grouted structure and definition of the geotechnical category.
5	Consideration of the relevant temporary phases of execution.
6	Assessment of the site investigation data with respect to design assumptions.
7	Assessment of the construction feasibility of the design.
8	Execution of trials if required and of any relevant tests.
9	Evaluation of the results of the preliminary trials and tests.
10	Selection of jet grouting system.
11	Assessment of the jet grouting system and definition of the working procedures.
12	Definition of the dimensions, location and orientation of jet grouted elements.
13	Instructions regarding the working sequence if required.
14	Definition of the working sequence.
15	Instruction to all parties involved of key items in the design criteria to which special attention should be directed.
16	Specification for monitoring the effects of jet grouting works on adjacent structures (type and accuracy of instruments, frequency of measurement) and for interpreting the results.
17	Definition of tolerable limits of the effects of jet grouting works on adjacent structures.
18	Execution of the jet grouting works, including monitoring of the jet grouting parameters.
19	Supervision of the works, including the definition of the quality requirements.
20	Monitoring the effects of jet grouting works on adjacent structures and presenting the results.
21	Control of the quality of works.

5 Geotechnical investigation

5.1 Jet grouting is a ground treatment method and shall be designed on the basis of the geotechnical characteristics of the ground ; therefore an accurate geotechnical investigation is essential.

5.2 All geotechnical investigation shall be undertaken in accordance with the requirements and recommendations of ENV 1997-1:1994, in particular with reference to the geotechnical categories in points 2.1, 3.2, and 3.3.

5.3 Where possible geotechnical investigation should be extended to the site boundaries so that the soil profile can be interpolated between the investigated axes rather than extrapolated outside them.

5.4 Special consideration shall be given to the following geotechnical conditions :

- firm or stiff cohesive layers or lenses ;
- high organic content ;
- swelling soils ;
- highly sensitive or quick clays ;
- cemented layers or lenses ;
- position of water table(s) ;

- presence of artesian or confined aquifer conditions ;
- high hydraulic gradients ;
- aggressive soil or water ;
- density of granular layers ;
- cobbles and/or boulders ;
- large voids or high permeability ;
- chemical wastes or deposits.

5.5 In addition to the lithology and structure of the ground in accordance with ENV 1997-1:1994, the following features and parameters shall also be determined, through laboratory and/or in situ tests, as applicable :

- grain size distribution, moisture content, Atterberg limits ;
- density, by direct or indirect measurement ;
- shear strength, by direct or indirect measurement.

5.6 In situ mechanical testing of the soil should be used to identify variations of density.

6 Materials

6.1 Unless otherwise specified, the properties of the materials shall comply with European standards.

6.2 Mixes composed of water and cement are usually adopted.

6.3 Hydraulic binders other than cement can be used.

6.4 In water/cement mixes the water/cement ratio by weight should range between 0,5 and 1,5.

6.5 Water reducing, stabilizing, plasticising, waterproofing or antiwashing admixtures can be added to the water/cement mix.

6.6 Other materials, such as bentonite, filler, fly-ash, can also be added to the mix.

6.7 When bentonite is to be used in the mix, a water/bentonite suspension should be prepared before adding cement.

6.8 Any recognized potable water is normally acceptable for the preparation of jet grouting mixes.

6.9 Water from sources other than recognized potable water suppliers shall be analysed in order to ensure that it will have no adverse effect on the setting, hardening or durability of the mix and, where applicable, will not promote corrosion of the reinforcement.

6.10 If the cement does not comply with the standard ENV 197-1:1992, appropriate tests shall be performed in order to ensure that the setting time, hardening, strength and durability requirements, as stated by design specifications, are met.

6.11 Care should be taken to ensure that no large particles are present in the jetting materials, as they can block the nozzles.

6.12 Acceptance criteria and water testing methods as required by subclause 6.9. shall conform to prEN 1008:1997.

6.13 Where reinforcement is obtained by steel bars, the material shall comply with ENV 1992-1-1:1991 - clause 3 and 6 as appropriate.

6.14 Where material other than steel bars is used for reinforcement, it shall comply with national standards or with design technical specifications.

7 Design considerations

7.1 General

7.1.1 Jet grouting can be applied in either temporary or permanent works for different purposes. For example :

- providing foundations for structures to be erected (Fig.5 a) ;
- underpinning existing foundations (Fig.5 b) ;
- creating low permeability barriers ;
- creating retaining or supporting structures ;
- complementing other geotechnical works ;
- reinforcing a soil mass.

7.1.2 The design of jet grouting works should specify that borehole collars are to be located above the water table.

7.1.3 Wherever the borehole collars are located below the water table or artesian head, special measures shall be taken into account, in order to avoid piping through the boreholes.

7.1.4 The purpose of jet grouting works shall be clearly defined in the design. The specified physical properties and geometry of jet grouted elements or structures shall be appropriate for this purpose.

7.1.5 The technical conditions which may influence the working sequence of the elements shall be specified.

7.1.6 When relevant, the detailed execution sequence should be shown on the execution drawings.

7.1.7 If the design of the jet grouting works cannot be completed due to deficient site investigation, and it is not possible to obtain the missing information by further soil investigation, an appropriate preliminary field test shall be specified.

7.1.8 Where no comparable previous experience is available representative preliminary field test shall be carried out, using the equipment, materials and techniques proposed for the main jet grouting works.

7.1.9 To ensure a consistent result in the preliminary in-situ trial, at least one jet grouted element should be constructed with a given working procedure. In significantly heterogeneous soil conditions more trial elements and different working procedures should be necessary for approval.

7.1.10 Where the jet grouted material is to be subjected to onerous conditions, such as high stresses or resistance to aggressive environments, the preliminary in-situ tests should be preceded by specified laboratory tests on samples of the soil to be treated and the grout, mixed in proportions encompassing the working range envisaged.

7.1.11 For mechanical tests on jet grouted material the conditions for testing the samples and the criteria for acceptance shall be specified.

7.1.12 Tolerances on specified performance parameters should take into account the accuracy of the proposed test methods, especially when these methods are indirect, as quoted in Annex C.

7.1.13 Whenever acceptance is defined on the basis of tests on core samples, the criteria for positioning and timing of the proposed corings in the jet grouted structure shall be specified in the design.

7.1.14 Design parameters should take account of construction difficulties which may reduce the effectiveness of the jet grouting.

7.1.15 Sequence and rate of execution, setting and hardening time, and diameter of columns shall be considered in order to avoid local soil failures or unacceptable settlement or uplift.

7.1.16 The design should define the acceptable limits of settlement, heave, distortion of structures and services likely to be affected by the jet grouted works.

7.1.17 The design of jet grouting works shall comply with Annex A.

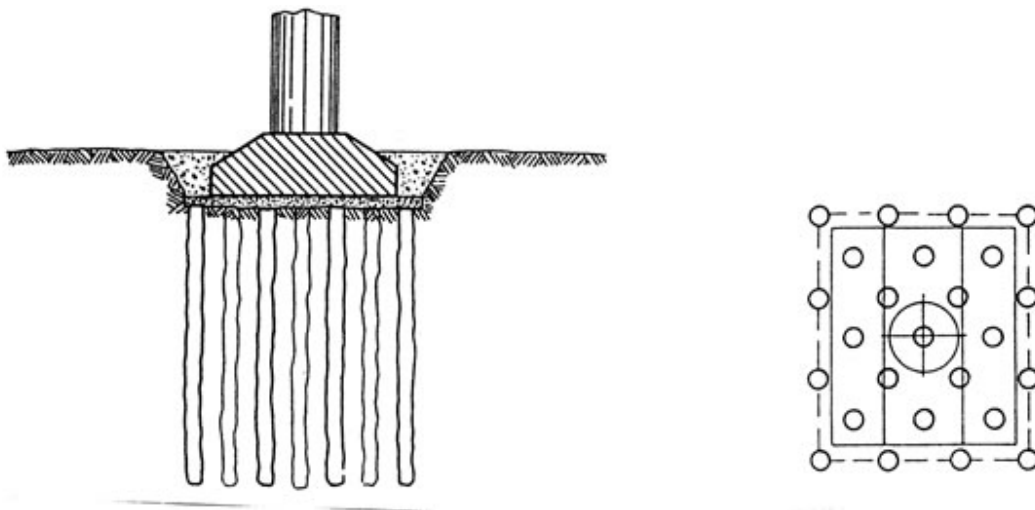

Figure 5 a) — Foundation for structure to be erected

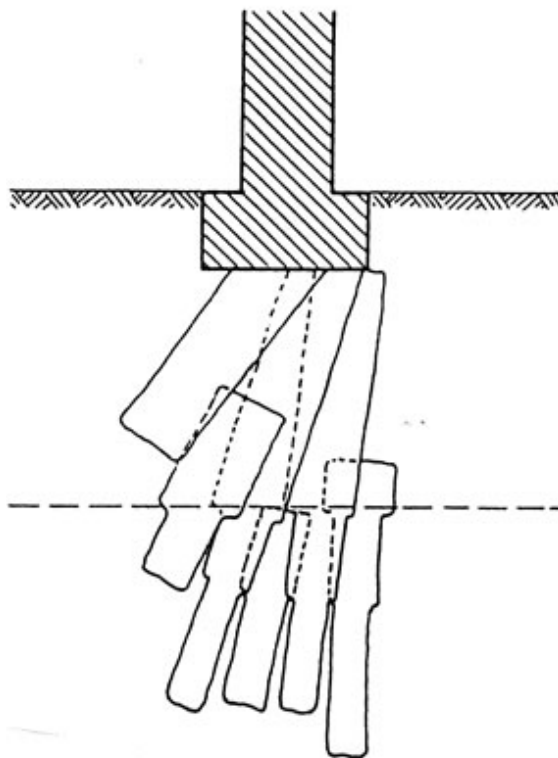

Figure 5 b) — Underpinning existing foundation

Figure 5 — Examples of applications

7.2 Geometry

7.2.1 The cross-sectional dimensions of a jet grouted element depend not only on the jet grouting system selected and on the parameters employed, but also on the soil type and its heterogeneity.

7.2.2 The design shall take into account the construction tolerances indicated in 8.4.3, 8.4.4, and 8.5.6, or shall propose different values for them.

7.2.3 The following shall be clearly shown on design drawings :

- minimum cross sectional dimensions of jet grouted elements to be achieved in the different soil layers that will be encountered ;
- tolerances on the position and inclination of the element axes (see 8.4.3 and 8.4.4).

7.2.4 Maximum cross sectional dimensions should also be considered and related to the element spacing to ensure the integrity of a jet grouted structure.

7.2.5 If any identified underground obstruction cannot be removed, the relevant area shall be marked on the design drawings, and the adjacent jet grouting treatment shall be designed so as to avoid unacceptable damage.

7.3 Strength and Deformation Characteristics

7.3.1 The strength of a jet grouted material depends both on the jet grouting system selected and on the parameters employed, and also on the soil type and its heterogeneity.

7.3.2 In underpinning applications stability and deformation in the temporary condition, prior to set, of the jet grouted columns beneath foundations shall be taken into account.

7.3.3 Where deformations of jet grouted elements or of jet grouted structures are an important concern, the design shall indicate the parameters to be measured in specified acceptance tests, the range of their values and the relevant mean values (mean on the element, on larger parts of the structure, on the whole structure).

7.3.4 The required statistical minimum strength of the mass should be established at the design stage, taking into consideration the variability of the soil conditions.

7.3.5 In many cases a practical degree of scatter will be unable to be set due to limited previous experience. In these circumstances a scatter can only be identified by on site tests.

7.3.6 Where indirect testing is to be used for checking the results the acceptance criteria shall be expressed in the design in terms of the actual parameters to be measured.

7.3.7 The jet grouted columns can be reinforced by high strength elements (bars, pipes, beams), installed during or after jet grouting operations.

7.4 Permeability

7.4.1 Where jet grouting works are employed to control groundwater, the results depend on the geometric accuracy of the elements and on the permeability of the jet grouted material.

7.4.2 Permeability requirements shall be expressed in the design in terms of limit values of parameters actually measured in specified acceptance tests.

The design shall specify the conditions of measurement of the jet grouted material permeability, and of the overall jet grouted structure.

7.4.3 The overall permeability of a jet grouted structure should be evaluated taking into account the effects of deformation due to excavation or to loading conditions at full scale.

8 Execution

8.1 General

8.1.1 The execution of jet grouting works requires knowledge and experience in this type of construction.

NOTE The high pressure employed in the jet grouting process is to generate a high speed jet to disaggregate the soil and is not intended to be applied to the surrounding soil.

8.1.2 Jet grouted column execution method

The phases of execution usually consist of :

- drilling a borehole of a predetermined length ;
- introducing to the end of the borehole a monitor connected to the jet grouting string. This is unnecessary in some cases as the string and monitor are used for drilling ;
- jetting of the disaggregating and cementing fluid(s) through the monitor, simultaneously withdrawing and rotating the rods, with pre-established withdrawal and rotational speed, pump pressure and flow rate for each fluid.

8.1.3 Jet grouted panel execution method

The phases of execution are the same as defined for jet grouted columns, with the exception that during jetting the rods are withdrawn and not rotated. Alternatively the rods can be rotated about limited angles. The resulting panel is placed in a plane on the drilling axis, or is formed by two or more sections on planes intersecting the drilling axis (Fig.1 b).

8.1.4 Alternative execution methods

If required by soil conditions, alternative execution methods may be adopted, both for column or panel processes. Among alternatives the most usual is prejetting. An element can also be executed in sequential steps: firstly the treatment for a given length from the borehole collar is completed and allowed to gain strength. Then, after redrilling the treated soil, the process is repeated at a deeper stage, and so on, until the design length of the treatment is reached.

8.1.5 Method statement

8.1.5.1 Before starting the jet grouting works, a method statement should be submitted. This method statement should contain the following information as a minimum :

- identification, objective and scope of the jet grouting works ;
- soil description ;
- shape of the jet grouted element required ;
- jet grouting system ;
- design of the jet grouting treatment ;
- working procedure (drilling, jetting, sequence of execution) ;
- jet grouting parameters ;
- materials (for drilling and jetting) ;
- precautions to be taken to avoid unacceptable settlement or heave, especially in silty and clayey soils ;
- site installation and working areas ;

- plant and equipment ;
- spoil management ;
- quality control procedures as required by the contract ;
- the measures taken to ensure the boring accuracy ;
- procedures regarding possible interruptions during the jetting operations ;
- the measures to be taken to ensure that the finished level of grouting is maintained during the initial set of the jet grouted material ;
- possible modifications of the jet grouting parameters during the works ;
- the testing methods ;
- working documents (drawings, reports).

8.1.5.2 For jet grouting works in geotechnical category 3 (ENV 1997-1:1994 - clause 2.1.) a method statement shall be submitted which shall include the information listed in **8.1.5.1**.

8.1.6 The ranges of the jet grouting parameters usually adopted for the different systems are listed in Annex B.

8.2 Equipment

8.2.1 The jet grouting equipment usually comprises :

- the drilling rig ;
- the jet grouting rig (often is also the drilling rig) provided with the jet grouting string, the monitor and the devices able to drive the jet grouting string at predetermined rotation and translation speeds ;
- the mixing and pumping plant supplying the jet grouting fluid (or fluids) ;
- the high pressure lines connecting the jet grouting pump to the rig ;
- equipment to monitor pressures, fluids flow rates and volumes, rate of rotation and withdrawal, depth.

8.2.2 The jet grouting equipment shall be able to perform the jet grouting operation as for the chosen process, by assuring :

- the translational and rotational movement of the jet grouting string with the designed speed ;
- the supply to the jet grouting string of the fluids coming from the plant, at the required pressure and rate of flow.

8.2.3 The length of the jet grouting string, and the height of the relevant mast, should not be shorter than the length of the designed jet grouted element. If imposed by large depths or by access limitations, the string should be divided into the minimum number of elements, in order to minimise the need to interrupt the jet grouting operation.

8.2.4 The jet grouting string :

- for the single system, one conduit conveying the high pressure the cement mix to the monitor ;
- for the double system, two conduits separately conveying the two fluids (air and cement mix, or water and cement mix respectively) to the monitor ;
- for the triple system, three conduits to allow for the high pressure water, the compressed air and the cement mix to the monitor.

Multiple conduits are assembled in the same rod.

8.2.5 The monitor comprises :

- for the single system, one or more circular nozzles for jetting the grout. Multiple nozzles are located at the same level or at different levels, with constant mutual staggered angles ;
- for the double (air) system, one or more double nozzles (located at the same level or at different levels, with constant mutual staggered angles) to allow the simultaneous jetting of air and grout. The air nozzle is an annulus around the circular nozzle for grout ;
- for the double (water) system, one or more nozzles for high pressure jetting of water and one or more deeper nozzles for sending the cement mix ;
- for the triple system, one or more double nozzles to allow the simultaneous jetting of air and water and one or more simple nozzles located at a deeper level to allow the grout injection.

In general the air-water and grout nozzles for each couple are set at 180° apart. Multiple couples are installed at constant mutual angles.

8.2.6 The jet grouting mixing and grouting plant, for the different systems, mainly comprises :

- for the single system : cement and other materials storage, colloidal mixing plant, agitator tanks, high pressure grout pump ;
- for the double (air) system: as for the single fluid system plus an air compressor ;
- for the double (water) system: as for the single fluid system plus a high pressure water pump and a grout pump ;
- for the triple system: as for the double fluid (water) system plus an air compressor.

8.3 Preliminary works

8.3.1 A stable and dry working platform should be provided.

8.3.2 The position of each jet grouting hole shall be accurately located and identified.

8.3.3 A system of collection and disposal of the spoil return should be provided.

8.3.4 For horizontal treatment measures to maintain the stability of the working face shall be taken.

8.3.5 The design assumptions concerning the geometry and structural condition of nearby structures shall be accurately verified before the jet grouting works are carried out.

8.4 Drilling

8.4.1 Drilling can be performed with air or water or muds or grouts or foams as flushing media. If required casing is used.

8.4.2 Where the borehole is unstable, or there is significant drill fluid loss, or where the soil conditions are otherwise likely to unduly inhibit spoil return, suitable preventative measures shall be adopted.

8.4.3 The deviation of the drilling starting point from the theoretical position shall be less than 50 mm, if not otherwise stated by the design specifications.

8.4.4 The deviation of drilling from the theoretical axis should be 2 % or less for depths up to 20 m. Different tolerances should apply for greater depths and for horizontal jet grouting.

8.4.5 The annular space between the drilled hole and the jet grouting string should be sufficient to permit a free flow of the spoil return to the borehole collar.

8.4.6 Where unexpected underground obstructions are encountered, appropriate measures should be taken, in order to avoid undesirable effects in the jet grouting phase.

8.5 Jet grouting

8.5.1 Jet grouting shall be executed and supervised by trained and experienced personnel.

8.5.2 For the panel method, the direction of adjacent elements should deviate from the average plane to facilitate the connection between the panels and consequently the continuity of the wall.

8.5.3 For the panel method, the orientation of the jetting nozzles shall be accurately controlled.

8.5.4 When bleeding is critical for jet grouting, the contact zone with the surrounding soil or structure should be verified.

8.5.5 In underpinning applications measures shall be taken to ensure that a final intimate contact is formed between the top surface of the jet grouted column and the underside of the foundation.

8.5.6 Jet grouting should be executed with a sufficient thickness between the upper nozzle and the ground surface, to avoid possible local hydrofracturing.

NOTE The above thickness may vary from 0,5 m for vertical boreholes to 2,0 m for horizontal boreholes and can be reduced in the presence of an adequate restraint to the surface, such as a slab or a wall.

8.5.7 For horizontal jet grouting the collar of the borehole shall be plugged as soon as jet grouting is completed.

8.5.8 When jet grouting an element is interrupted for any reason, the re-start shall be undertaken using procedures that are intended to ensure the continuity of the element.

8.6 Spoil Return

8.6.1 During jet grouting a visual observation of the flow and features of the spoil return at hole collar shall be maintained.

8.6.2 Further control may be achieved by measurement of specific physical or chemical properties of the spoil return.

8.6.3 If during the jet grouting unexpected behaviour of the spoil return is observed, the jet grouting parameters and/or method should be reviewed.

8.6.4 An unexpected reduction in spoil return shall be investigated and dealt with immediately. It can be caused by clogging of the annulus of the jetting borehole.

8.7 Placing the reinforcement

Reinforcement can be installed in the fresh jet grouted material during or immediately after the completion of the jet grouting operations. Alternatively it can be installed in a borehole drilled into the element after hardening.

9 Supervision, testing and monitoring

9.1 General

9.1.1 The following characteristics of jet grouted elements should be monitored for control purposes :

— geometry ;

and, where appropriate :

— strength, deformability, permeability or density of the jet grouted material.

9.1.2 It is generally impractical or impossible to measure the dimensions and material properties directly on a statistically significant number of jet grouted elements.

9.1.3 The minimum quality control of jet grouting shall consist of reporting the jet grouting parameters and observing the spoil return on all elements.

9.1.4 It may be assumed that in comparable soil conditions the same jet grouting parameters produce the same element dimensions, properties and spoil return.

9.1.5 In jet grouting works, after the first few elements have been produced, measures of the dimensions and material properties should be taken on a limited number of elements to establish the relationship between the jet grouting parameters and the element properties.

9.1.6 Where comparable experience (as defined by ENV 1997-1:1994 - clause 1.5.2.) on the same jet grouting system in similar ground conditions is available, testing after execution may be omitted, if the design specifications do not require it and provided that monitoring of jet grouting parameters is applied to the jet grouted elements of the work.

9.2 Preliminary tests

9.2.1 Where comparable experience is not available, an appropriate preliminary field test shall be designed and performed. It shall cover all relevant conditions likely to be encountered on the site, in order to :

- enable a selection of the most effective system and jet grouting parameters ;
- verify that the results conform to the design requirements using the selected system and jet grouting parameters.

9.2.2 Where preliminary tests are performed, if excavation is possible, assessment of the geometric and mechanical characteristics of the jet grouted elements should be made by visual inspection of the exposed jet grouted elements and by laboratory tests on samples recovered by coring or excavation.

9.2.3 Where preliminary tests are performed, if the jet grouted elements cannot be exposed, the assessment of the results (mainly the size of the elements) should be made by coring or by direct measurement prior to setting, or by indirect tests.

9.2.4 If coring or above indirect tests are applied to check the "as built" geometry of the elements of the main works, and visual inspection of preliminary elements is possible, the same methods should be applied also to the preliminary elements and their results should be compared with visual inspection, to check the reliability of the methods.

9.2.5 Indirect tests and laboratory tests performed on samples recovered by coring should be selected with care, having regard to the practical limitations to their reliability.

9.2.6 Annex C lists some indirect tests that can be applied.

9.3 Supervision and process testing

9.3.1 Pressure gauges and other meters to be used in the measurements of the jetting parameters shall be calibrated before commencement of the works.

9.3.2 The pressure of the fluids is commonly measured as pump pressure. In cases where long lines or very deep treatment is necessary the head losses should be taken into account.

9.3.3 For long duration contracts periodic calibration of the instruments can be required for quality control.

9.3.4 The inclination of the jet grouted elements shall be assessed by measuring the inclination of the jet grouting string at the surface before and during drilling, if not otherwise stated by the design.

9.3.5 The spoil return flow and features shall be visually observed and the description recorded.

9.3.6 The density of the spoil return should be periodically measured and recorded. The reasons for any unexpected results should be explored.

9.3.7 Representative samples of the spoil return should be taken and submitted to compression tests.

9.3.8 The following tests on the grout mix should be performed :

- preliminary tests :
 - density ;
 - bleed (3 hours on 1 000 cm³, 60 mm diameter, cylinder) ;
 - marsh viscosity ;
 - setting time ;
 - unconfined compression tests on cylindrical samples (height/diameter ratio 2,0) at 3, 7, 28 days ; 56 days if slowly hardening mixes are used ;
- tests during the work :
 - density (minimum twice a shift) ; Marsh viscosity (daily) ;
 - bleeding (daily).

9.4 Testing on the constructed elements

9.4.1 Testing to assess geometry

9.4.1.1 Visual inspection and direct measurement are the most effective ways of assessing the dimensions. This requires large excavations preferably down to the full depth of the element and therefore is rarely feasible on elements to be incorporated in the work.

9.4.1.2 Wherever visual inspection is not possible, information about the cross-sectional dimensions of an element can be obtained from coring or drilling with measurement of drilling rate, inclined to the element axis.

9.4.1.3 The length of an element can be detected by coring or drilling or penetration testing parallel to its axis. This is increasingly difficult with slenderness, and is practically excluded where the ratio of length to diameter exceeds 15.

9.4.1.4 When coring is performed, the inclination of the coring axis should be measured, and the location and inclination of the jet grouted element axis should previously have been determined.

9.4.1.5 Coring shall be performed only after sufficient hardening time is elapsed.

9.4.1.6 The method of coring, the equipment used and the size of the cores shall be such as to ensure that representative samples are obtained. Special precautions are necessary when coring jet grouted elements formed in clayey/silty soils or in heterogeneous soils (containing cobbles for instance) or if the jet grouted material is of low strength.

9.4.2 Mechanical tests

9.4.2.1 Where in situ tests are used to measure the mechanical characteristics of the jet grouted material (penetrometer, pressuremeter or any other test requiring to drill through), the position of the measuring tool shall be defined referring to the element geometry and lay-out.

9.4.2.2 Compression tests shall be performed on samples with height to depth ratio of 2,0.

9.4.2.3 Where relevant, the compressive strength of the jet grouted structures should be assessed by testing four samples taken from the structure for each 1 000 m³ of its volume, if not otherwise specified by the design.

9.4.2.4 Where mechanical properties are obtained from tests on cores, care should be taken to allow for the effects of sampling, trimming and test procedures.

9.4.2.5 The tendency of the strength and modulus to increase with time is strongly dependent on the soil type, with longer development for higher fines content.

9.4.2.6 Brazilian traction tests¹⁾ and shear tests can also be performed on cores if required by the specific application.

9.4.2.7 In situ loading tests of the jet grouted elements can be appropriate where they are to be used as deep foundations.

9.4.2.8 Mechanical tests shall be performed at appropriate times after set of the jet grouted material, taking into account both the construction requirements and the influence of the nature of the soil on the hardening time of the jet grouted material.

9.4.2.9 Samples taken for mechanical tests should be stored under controlled moisture and temperature conditions.

9.4.3 Permeability tests

9.4.3.1 The overall watertightness of jet grouted structures should be assessed by pumping tests and/or piezometric readings.

9.4.3.2 The overall watertightness of a jet grouted structure around and/or below an excavation in geotechnical categories 2 and 3 shall be assessed by pumping tests and piezometric readings before any excavation below the original ground water level is undertaken.

9.4.3.3 The permeability of the elements can be measured by borehole water tests.

9.5 Monitoring

9.5.1 Monitoring of the jet grouting parameters during the performance of jet grouting works is essential for the quality control of the results.

9.5.2 For applications in geotechnical categories 2 and 3, the following parameters shall be continuously recorded for all elements, except for short periods during unavoidable equipment faults :

- pressures and flows of the fluids ;
- translation and rotation speed of the monitor.

9.5.3 When jet grouting works have to be performed in situations where there is a high risk of unacceptable deformations of adjacent structures, monitoring and alarm systems shall be employed.

9.5.4 For underpinning applications the buildings to be underpinned should be monitored by repeated levelling or by automatic settlement sensors.

10 Execution documents

10.1 Documents available on site

10.1.1 The following documents shall be available on site prior to the main jet grouting works :

- technical specifications ;
- execution drawings ;
- method statement, if required (see 8.1.5) ;
- a geotechnical report describing the subsoil conditions ;

1) The Brazilian test is run on a cylindrical sample (H/D ratio = 0,5) submitted to compression along a diameter plane and is interpreted in terms of tensile strength of the tested material.

- technical specification of the jet grouting plant ;
- a description of the characteristics of the materials ;
- a report on preliminary tests, where performed.

10.1.2 The jet grouting execution drawings shall contain the following information :

- the soil profile ;
- the shape of the elements ;
- the number of the elements, a clear reference number for each ;
- the location and orientation of each element, and tolerances on position ;
- the location of possible underground obstructions, services and drainage ;
- the execution sequence, where relevant.

10.2 Documents to be produced on site

10.2.1 Records of the jet grouting execution shall be compiled for future reference. They shall cover for each element :

- the jet grouting parameters ;
- comments on the spoil return ;
- unexpected features ;
- date and time of execution.

NOTE Examples of site records are given in Annex D.

10.2.2 Where in-situ preliminary trials have been performed, a detailed report shall be prepared, including all the results obtained with reference to the prevailing soil conditions and the size of the jet grouted elements to be constructed.

10.2.3 The jet grouting execution plan and all records shall be kept after the completion of the works.

11 Special requirements

11.1 Compliance with national standards

The execution of jet grouting works shall comply with all national standards, specifications or statutory requirements regarding :

- security of the site ;
- safety of the working procedures ;
- operational safety of drilling, jet grouting and auxiliary equipment and tools ;
- environmental protection.

11.2 Site safety

11.2.1 Appropriate measures shall be taken to protect the health and safety of the workers and of other people present on and adjacent to the site.

11.2.2 Legislation of European Countries shall be adhered to; health and safety hazards associated with jet grouting shall be assessed on a site specific basis.

11.3 Protection of the environment

11.3.1 Measures shall be taken in order to limit or avoid adverse effects on the environment.

NOTE Attention is drawn to national standards and statutory requirements concerning environmental protection.

11.3.2 The following risks to the environment shall be considered :

- induced movement in the ground or in adjacent structures ;
- pollution of surface water and groundwater ;
- unacceptable changes in the natural groundwater flow ;
- air pollution ;
- noise.

11.3.3 Methods of handling the spoil, including :

- collection at the borehole surface ;
- temporary storage on the site ;
- possible treatment ;
- final disposal ;

shall be such as to minimise adverse effects on the environment.

Annex A (normative)

Additional design requirements

A.1. The design shall take into account the anticipated stresses in the jet grouted element and the effects of variability of the soil on the strength of the elements.

A.2. The design shall verify the overall stability of jet grouted elements and structures used for underpinning or as retaining walls, including the partial safety concept of ENV 1997-1:1994.

Annex B (informative)

Ranges of jet grouting parameters

The jet grouting parameters usually adopted for the different systems fall within the following ranges :

Jet grouting parameters	Single fluid	Double fluid (air)	Double fluid (water)	Triple fluid
Grout pressure (MPa)	30 to 50	30 to 50	> 2	> 2
Grout flow rate (l/min)	50 to 450	50 to 450	50 to 200	50 to 200
Water pressure (MPa)	N/A	N/A	30 to 60	30 to 60
Water flow rate (l/min)	N/A	N/A	50 to 150	50 to 150
Air pressure (MPa)	N/A	0,2 to 1,7	N/A	0,2 to 1,7
Air flow rate (m ³ /min)	N/A	3 to 12	N/A	3 to 12
N/A Not applicable.				

The disaggregating effect is obtained by the high velocity of the jet, mainly dependent on the pressure of the fluid used for the disaggregation : grout in single and double (air) fluid systems, water in double (water) and triple fluid systems.

For single and double (air) fluid systems, grout pressure usually ranges between 30 MPa and 50 MPa, as defined in the table above. Lower limits down to 10 MPa have also been adopted in particular cases, such as small diameter jet grouted columns in very loose soils.

NOTE The most recent developments in pumping equipment enable the pressure of the disaggregating fluid to reach up to 70 MPa or flow rates up to 650 l/min.

Annex C **(informative)**

Indirect tests

- C.1.** Cross-hole geophysical tests can be performed with the aim of checking the continuity of a series of interlocked jet grouted elements.
- C.2.** When high geometric accuracy is required, the alignment of the boreholes for geophysical tests or coring can be checked by borehole deviation measurements.
- C.3.** Both p-wave and s-wave velocities should be measured when performing cross-hole tests.
- C.4.** Values of E and G moduli in the strain field of microdeformations ($\varepsilon < 10^{-4}$) can be indirectly obtained from the velocity measurements from cross-hole tests.
- C.5.** The geometry of a jet grouted element can also be assessed by CPT's (static cone penetration tests) performed through the element before set. This method applies mainly to jet grouted elements created in soil with high penetration resistance compared with the low resistance of the fresh grouted material.
- C.6.** Other test methods can be used in certain cases; examples include SPTs (standard penetration tests), dynamic cone, or pressuremeter.

Annex D **(informative)**

Examples of site records of jet grouting works

NOTE The daily reports presented in this annex give an example of technical site documents for the execution of jet grouted columns, reflecting one of the possible choices of site organisation and of operation mode of the jet grouting string.

Two reports are presented, as often one mixing and pumping plant alternatively feeds one rig in the jet grouting phase, while one or more other rigs are performing drilling in the same site.

The jet grouting string can be withdrawn by a continuous or by a step-by-step movement. The second mode is reflected by the jet rig report in the annex, where a step length (usually few centimetres) and a time per step (usually ranging from few seconds to 40» or more, depending on column diameter, type of soil and of jet grouting system) are recorded.

Jet plant daily report

SITE :	ZONE	Pump type :								
DATE :		Supervisor :								
Shift from	to	Signature :								
Supervisor instructions										
	Value	Grouter		Grout control						
Water pressure (bar)				Time	Density (kg/l)					
Water flow (l/min)										
Grout pressure (bar)										
Grout flow (l/min)										
	Grout A	Grout B								
Cement/batch (kg)										
Water/batch (kg)										
Batch mass (kg)										
Batch volume (l)										
Grout density (kg/l)										
Grouter controls										
Column N°	Counter start drilling	Counter end drilling	Counter start prejetting	Counter end prejetting	Counter start jetting	Counter end jetting	Time start jetting	Time end jetting	Water pressure	Grout pressure
Stoppages						N° batches prepared =				
Time start	Time end	Nature of stoppage				Others observations				
						Grouter : Signature :				

Jet rig daily report

SITE : ZONE				Rig type :												
DATE :				Supervisor :												
Shift from to				Signature :												
Supervisor instructions										Sequence of execution of the columns						
		Prejetting			Jetting			Driller								
Depth column toe (m)																
Depth column head (m)																
Nozzle diameter (mm)																
Step length (cm)																
Time per step (s)																
Rotation speed (rpm)																
Water pressure (bar)																
Water flow (l/min)																
Grout pressure (bar)																
Grout flow (l/min)																
Air pressure (bar)																
Driller controls																
Column N°	Column Incli- naison	Time start drill	Time end drill	Depth end drill	Time start prejet	Time end prejet	Time start jet	Time end jet	Depth end jet	Water pressure	Grout pressure	Step length	Time per step	Air pressure		
Spoils measurements																
Column N°	Depth	Spoil density			Samples moulded N°			Others observations								
							Driller :									
							Signature :									

Annex E (informative)

Degree of obligation of the provisions

The provisions are marked corresponding to their degree of obligation :

- RQ : requirement ;
- RC : recommendation ;
- PE : permission ;
- PO : possibility and eventuality ;
- ST : statement.

1 Scope : ST

2 Normative references : ST

3 Terms and definitions

3.1 – 3.20 : ST

4 Specific needs

4.1 : RQ
4.2 : RQ
4.3 : PO
4.4 : RQ
4.5 : RC

5 Geotechnical investigation

5.1 : RQ
5.2 : RQ
5.3 : RC
5.4 : RQ
5.5 : RQ
5.6 : RC

6 Materials

6.1 : RQ
6.2 : ST
6.3 : PO
6.4 : RC
6.5 : PO
6.6 : PO
6.7 : RC
6.8 : ST
6.9 : RQ
6.10 : RQ
6.11 : RC
6.12 : RQ
6.13 : RQ
6.14 : RQ

7 Design considerations

7.1 General
7.1.1 : ST
7.1.2 : RC
7.1.3 : RQ
7.1.4 : RQ
7.1.5 : RQ
7.1.6 : RC
7.1.7 : RQ
7.1.8 : RQ
7.1.9 : RC
7.1.10 : RC
7.1.11 : RQ
7.1.12 : RC
7.1.13 : RQ
7.1.14 : RC
7.1.15 : RQ
7.1.16 : RC
7.1.17 : RQ
7.2 Geometry
7.2.1 : ST
7.2.2 : RQ
7.2.3 : RQ
7.2.4 : RC
7.2.5 : RQ
7.3 Strength and deformation characteristics
7.3.1 : ST
7.3.2 : RQ
7.3.3 : RQ
7.3.4 : RC
7.3.5 : ST
7.3.6 : RQ
7.3.7 : PO
7.4 Permeability
7.4.1 : ST
7.4.2 : RQ
7.4.3 : RC

8 Execution

8.1 General
8.1.1 : ST
8.1.2 : ST
8.1.3 : ST
8.1.4 : ST
8.1.5 Method statement
8.1.5.1 : RC
8.1.5.2 : RQ
8.1.6 : ST
8.2 Equipment
8.2.1 : ST
8.2.2 : RQ
8.2.3 : RC
8.2.4 : ST
8.2.5 : ST
8.2.6 : ST
8.3 Preliminary works
8.3.1 : RC
8.3.2 : RQ
8.3.3 : RC
8.3.4 : RQ
8.3.5 : RQ
8.4 Drilling
8.4.1 : ST
8.4.2 : RQ
8.4.3 : RQ
8.4.4 : RC
8.4.5 : RC
8.4.6 : RC
8.5 Jet grouting
8.5.1 : RQ
8.5.2 : RC
8.5.3 : RQ
8.5.4 : RC
8.5.5 : RQ
8.5.6 : RC
8.5.7 : RQ
8.5.8 : RQ

8.6 Spoil return
8.6.1 : RQ
8.6.2 : PO
8.6.3 : RC
8.6.4 : RQ
8.7 Placing the reinforcement :
PO

9 Supervision, testing and monitoring

9.1 General
9.1.1 : RC
9.1.2 : ST
9.1.3 : RQ
9.1.4 : PE
9.1.5 : RC
9.1.6 : PE
9.2 Preliminary tests
9.2.1 : RQ
9.2.2 : RC
9.2.3 : RC
9.2.4 : RC
9.2.5 : RC
9.2.6 : ST
9.3 Supervision and process testing
9.3.1 : RQ
9.3.2 : RC
9.3.3 : PO
9.3.4 : RQ
9.3.5 : RQ
9.3.6 : RC
9.3.7 : RC
9.3.8 : RC
9.4 Testing on the constructed elements
9.4.1 Testing to assess geometry

9.4.1.1 : ST
9.4.1.2 : PO
9.4.1.3 : PO
9.4.1.4 : RC
9.4.1.5 : RQ
9.4.1.6 : RQ
9.4.2 Mechanical tests
9.4.2.1 : RQ
9.4.2.2 : RQ
9.4.2.3 : RC
9.4.2.4 : RC
9.4.2.5 : ST
9.4.2.6 : PO
9.4.2.7 : PO
9.4.2.8 : RQ
9.4.2.9 : RC
9.4.3 Permeability tests
9.4.3.1 : RC
9.4.3.2 : RQ
9.4.3.3 : PO
9.5 Monitoring
9.5.1 : ST
9.5.2 : RQ
9.5.3 : RQ
9.5.4 : RC

10 Execution documents

10.1 Documents available on site
10.1.1 : RQ
10.1.2 : RQ
10.2 Documents to be produced on site
10.2.1 : RQ
10.2.2 : RQ
10.2.3 : RQ

11 Special requirements

11.1 Compliance with national standards
11.1.1 : RQ
11.2 Site safety
11.2.1 : RQ
11.2.2 : RQ
11.3 Protection of the environment
11.3.1 : RQ
11.3.2 : RQ
11.3.3 : RQ

Annex A (normative) Additional design requirements

A.1 : RQ
A.2 : RQ

Annex B (informative) Ranges of jet grouting parameters

Annex C (informative) Indirect tests

C.1 : PO
C.2 : PO
C.3 : RC
C.4 : ST
C.5 : PO
C.6 : PO

Annex D (informative) Examples of site records of jet grouting works

Annex E (informative) Degree of obligation of the provisions

Bibliography

EN 196, *Methods of testing cement.*

BSI — British Standards Institution

BSI is the independent national body responsible for preparing British Standards. It presents the UK view on standards in Europe and at the international level. It is incorporated by Royal Charter.

Revisions

British Standards are updated by amendment or revision. Users of British Standards should make sure that they possess the latest amendments or editions.

It is the constant aim of BSI to improve the quality of our products and services. We would be grateful if anyone finding an inaccuracy or ambiguity while using this British Standard would inform the Secretary of the technical committee responsible, the identity of which can be found on the inside front cover. Tel: 020 8996 9000. Fax: 020 8996 7400.

BSI offers members an individual updating service called PLUS which ensures that subscribers automatically receive the latest editions of standards.

Buying standards

Orders for all BSI, international and foreign standards publications should be addressed to Customer Services. Tel: 020 8996 9001. Fax: 020 8996 7001. Standards are also available from the BSI website at <http://www.bsi-global.com>.

In response to orders for international standards, it is BSI policy to supply the BSI implementation of those that have been published as British Standards, unless otherwise requested.

Information on standards

BSI provides a wide range of information on national, European and international standards through its Library and its Technical Help to Exporters Service. Various BSI electronic information services are also available which give details on all its products and services. Contact the Information Centre. Tel: 020 8996 7111. Fax: 020 8996 7048.

Subscribing members of BSI are kept up to date with standards developments and receive substantial discounts on the purchase price of standards. For details of these and other benefits contact Membership Administration. Tel: 020 8996 7002. Fax: 020 8996 7001. Further information about BSI is available on the BSI website at <http://www.bsi-global.com>.

Copyright

Copyright subsists in all BSI publications. BSI also holds the copyright, in the UK, of the publications of the international standardization bodies. Except as permitted under the Copyright, Designs and Patents Act 1988 no extract may be reproduced, stored in a retrieval system or transmitted in any form or by any means – electronic, photocopying, recording or otherwise – without prior written permission from BSI.

This does not preclude the free use, in the course of implementing the standard, of necessary details such as symbols, and size, type or grade designations. If these details are to be used for any other purpose than implementation then the prior written permission of BSI must be obtained.

If permission is granted, the terms may include royalty payments or a licensing agreement. Details and advice can be obtained from the Copyright Manager. Tel: 020 8996 7070.